

# GCA-C0245P

Motorized Dome Day/Night Camera, 36x Zoom, WDR



- 36x motorized optical zoom with 12x digital zoom
- High Speed Pan/Tilt (400°/sec), minimum speed (0.5°/sec)
- WDR function, Colour/B&W function with removable IR cut filter
- 650 TV Lines
- Digital Noise Reduction
- RS485 - Multiprotocol
- For indoor and outdoor use

## SUMMARY

---

The GRUNDIG Swiftdome Cameras are suitable for both outdoor and indoor use. The robust vandal resistant housing with sun shield protects the camera not only against weather but also against physical attacks. Of course, the cameras also offer a variety of alarm inputs and a privacy zone function. Even in difficult lighting situations, the cameras are able to provide superior images. Due to the large focal length range of the zoom module and the fast rotation motor, the cameras are particularly suitable for monitoring large outdoor areas, spacious warehouses, supermarkets, or driveways. Even at great distances, individuals can be identified or perceived.

When positioned correctly, one GRUNDIG Swiftdome Camera allows you to save a multitude of fix cameras.

## SPECIFICATIONS

Image Sensor	1/4" CCD (Super HAD 2 CCD)
Pixels - Total	976x582 (570k)
Resolution	650 (H) lines
Col/B&W	On/Off/Auto, IR-cut filter removable (ICR)
Sensitivity	0.1 lux (Colour) / 0.01 lux (B&W)
Aperture Ratio	F 1.6 ~ C
Focal Length	3.4 ~ 122.4 mm
Zoom Ratio	x 36
Digital Zoom	Off/1 ~ 12x
Lens Drive Type	Auto iris (DC)
BLC	On/Off
WDR	ON/OFF
White Balance	Auto / Manual
Camera ID	20 character
Number of Privacy Zones	16
Pan Speed	Manual: 0.5°/s ~ 90°/s, Preset: 400°/s (max.)
Tilt Speed	Manual: 0.5°/s ~ 90°/s, Preset: 400°/s (max.)
Range Panning	360° endless
Range Tilting	-10° ~ 190°
Number of Preset	256
Number of Pattern	8
OSD	Yes
Alarm Inputs	4
Alarm Outputs	1
Regulation	CE, FCC, RoHS Compliant
Protection Rating	IP66 / IK10
Operating Temperature	-45°C ~ +50°C
Humidity	less than 90%
Supply Voltage	24 VAC
Power Consumption	65 W
Weight	2.6 kg
Dimensions w*h*d	ø190 x 302.5 mm

## DIMENSIONS

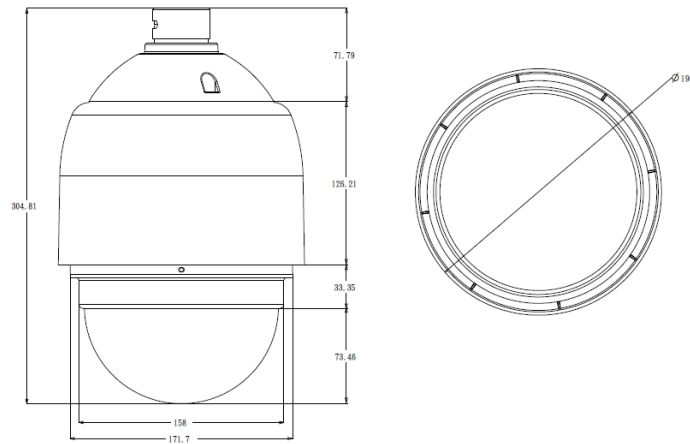

## ACCESSORIES



GBR-WA02  
Wall Bracket for Motor Dome Cameras



GBR-AM02  
Adapter Ring for Pelco Pendant Mount  
with 1,5" NPT thread



GBR-PM01  
Pole Mount Adapter



GBR-CM01  
Corner Mount Adapter



GBR-CE01  
Pendant Mount Bracket