



EN

# User Manual

**Wall bracket for LCD monitors,  
32" - 65", VESA, max. 50 kg**

**VM-LCDWMB1**

# Package contents

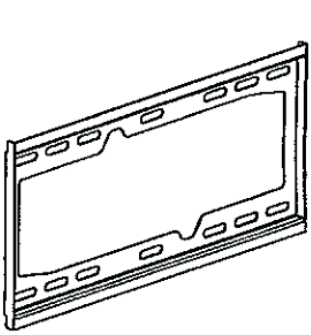



1pc









1pc



1pc

		
D 4 pcs	E 4pcs	F 4 pcs

					
a-M4X30 4pcs	b-M6X30 4pcs	c-15mm 4pcs	d-5mm 4pcs	e--M6/M8 4pcs	f-4mm 1pc

# Installation Step:

1.

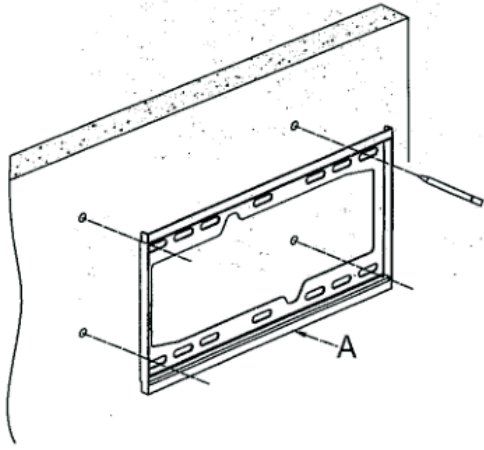

Keep the wallboard level

2.

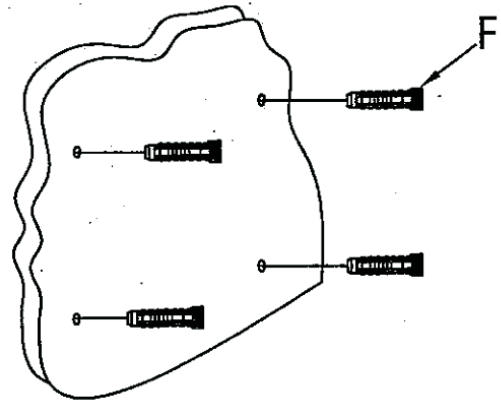
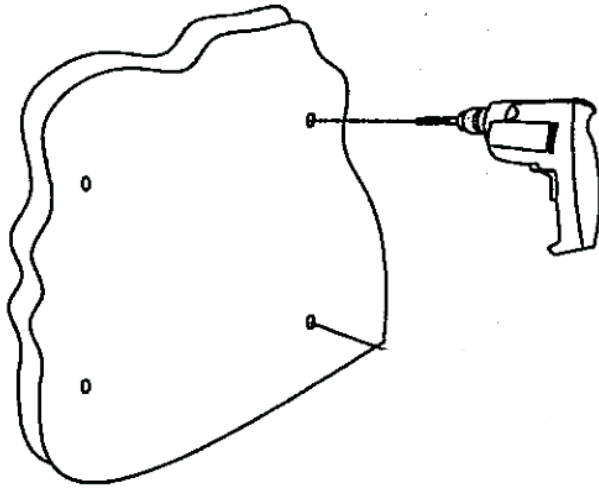

Hole with a diameter of 10mm and a depth of 50mm

3.

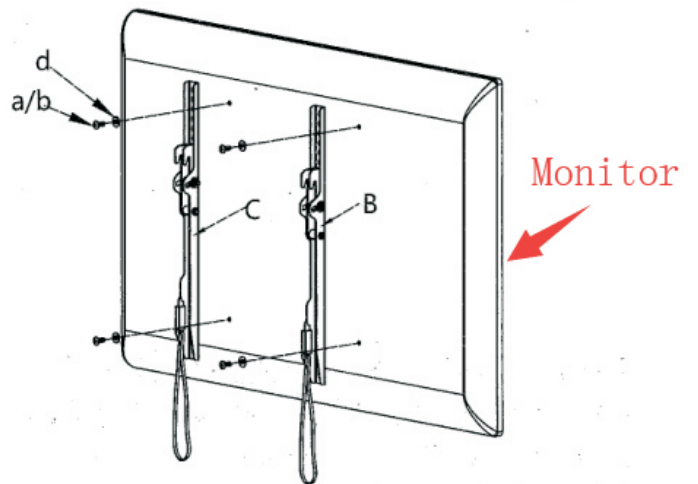
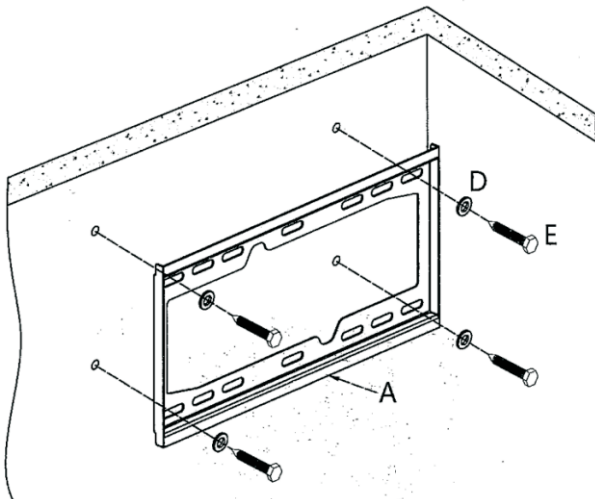

4.

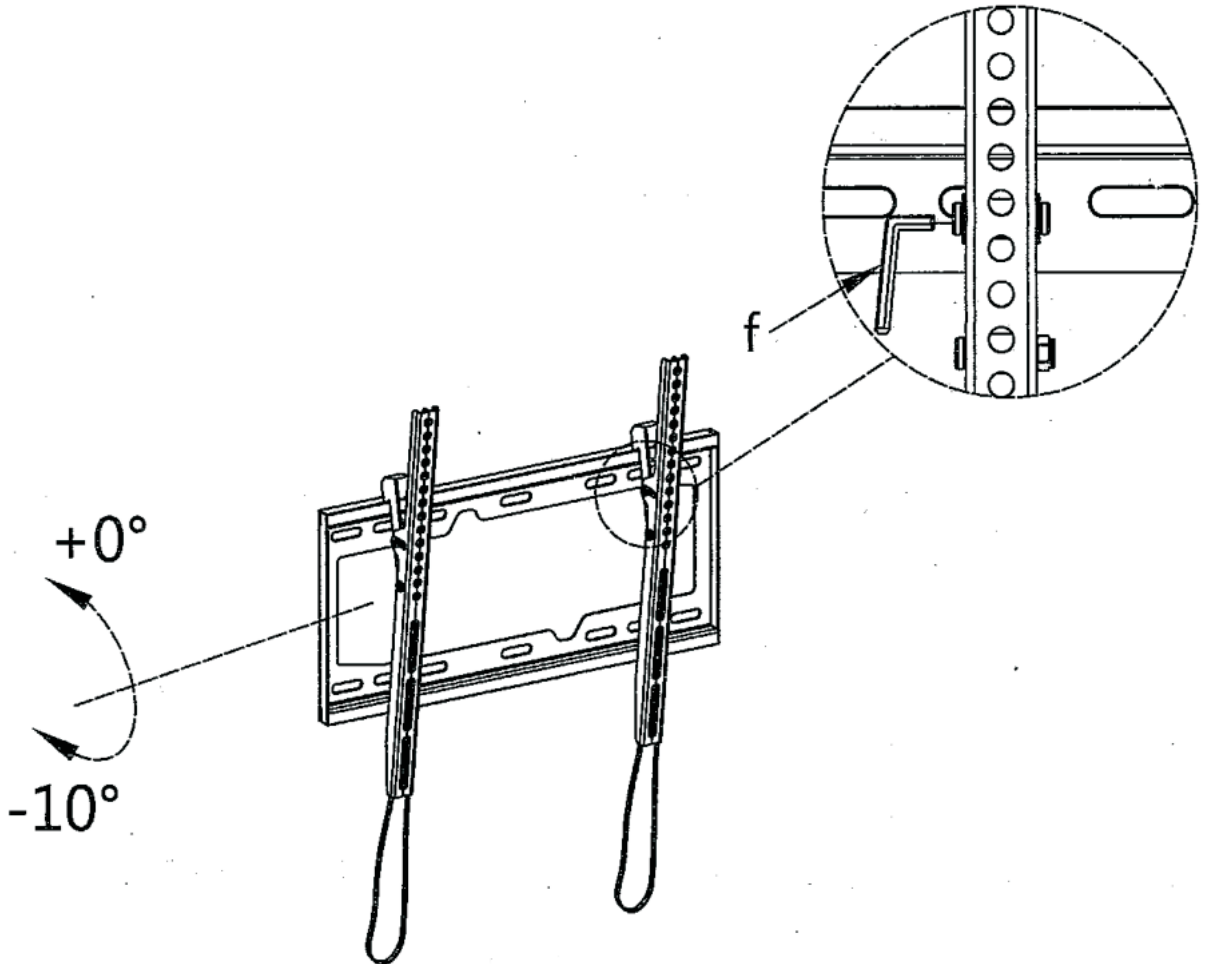
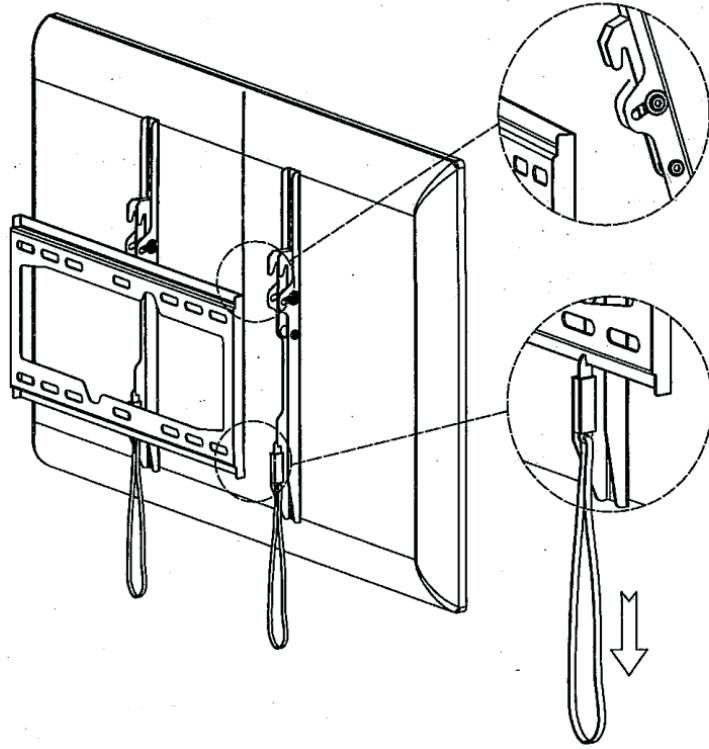

Additional Accessory:



4x M4 washer



4x M4x15 screw



4x M6x15 screw



eneo® is a registered trademark of  
VIDEOR E. Hartig GmbH  
Exclusive distribution through special-  
ised trade channels only.

VIDEOR E. Hartig GmbH  
Carl-Zeiss-Straße 8  
63322 Rödermark/Germany  
Tel. +49 (0) 6074 / 888-0  
Fax +49 (0) 6074 / 888-100  
[www.videor.com](http://www.videor.com)  
[www.eneo-security.com](http://www.eneo-security.com)

Technical changes reserved

© Copyright by VIDEOR E. Hartig  
GmbH Version 01/2020